

**ONYX-
MM-
DIO** Low-
Cost 48-Line
Digital I/O
PC/104
Module



DIAMOND
S Y S T E M S

 **PC104**



FEATURES

- 48 digital I/O lines
- Programmable port directions
- 10K Ω pull-up resistors on each line
- All lines power up in input mode
- Dual 50-pin I/O headers
- Low cost
- Software and technical manual included
- 40°C to +85°C extended temperature

Description

Onyx-MM-DIO has 48 digital I/O lines using 2 82C55 ICs. Each chip has 24 I/O lines organized as three 8-bit ports, A, B, and C. All I/O lines are connected to 10KOhm pull-up resistors, and on power-up or system reset, all ports reset to input and are pulled high. A control register on the 82C55 chip allows you to program each port for input or output and for different operating modes, including basic I/O, strobed I/O, and bit set/reset.

Mode 0 operation provides basic input and output operations. No handshaking signals are used. This is the most common method of digital I/O and is useful for reading status signals, turning switches on and off, etc. All three ports can operate in Mode 0.

Mode 1 operation provides strobed I/O on ports A and B with handshaking signals provided on port C. In input mode, one signal is a strobe to latch data into the port, and a second signal is an acknowledge output. In output mode, one signal is used to indicate that the CPU has written new data to the port, and a second signal is an acknowledge input.

Mode 2 operation allows the use of Port A as a bidirectional data bus, with port C lines used for handshaking. Port A is normally in tristate mode. When the CPU writes new data to port A, an output signal indicates new data is available. In response, the external

circuit strobes an acknowledge input signal, thereby enabling the output buffers on Port A. The external circuit can also latch new data into Port A with an input data strobe signal.

Bit set/reset mode enables individually setting (1) or resetting (0) any bit on Port C without having to read Port C and mask or protect unaltered bits.

Diamond's free Universal Driver software provides a comprehensive C programming library to control all the digital I/O features. Example programs are included with both source code and executables to assist you in developing your application quickly.

◆ I/O Header Pinout

Onyx-MM-DIO contains 2 50-pin I/O headers with 24 I/O lines organized as 3 8-bit ports on each header. 5V power and Ground pins are also provided on each header.

J3 (Right Side)

(Port A) A7	1	2	Ground
A6	3	4	Ground
A5	5	6	Ground
A4	7	8	Ground
A3	9	10	Ground
A2	11	12	Ground
A1	13	14	Ground
A0	15	16	Ground
(Port C) C7	17	18	Ground
C6	19	20	Ground
C5	21	22	Ground
C4	23	24	Ground
C3	25	26	Ground
C2	27	28	Ground
C1	29	30	Ground
C0	31	32	Ground
(Port B) B7	33	34	Ground
B6	35	36	Ground
B5	37	38	Ground
B4	39	40	Ground
B3	41	42	Ground
B2	43	44	Ground
B1	45	46	Ground
B0	47	48	Ground
+5V	49	50	Ground

J4 (Left Side)

(Port D) D7	1	2	Ground
D6	3	4	Ground
D5	5	6	Ground
D4	7	8	Ground
D3	9	10	Ground
D2	11	12	Ground
D1	13	14	Ground
D0	15	16	Ground
(Port F) F7	17	18	Ground
F6	19	20	Ground
F5	21	22	Ground
F4	23	24	Ground
F3	25	26	Ground
F2	27	28	Ground
F1	29	30	Ground
F0	31	32	Ground
(Port E) E7	33	34	Ground
E6	35	36	Ground
E5	37	38	Ground
E4	39	40	Ground
E3	41	42	Ground
E2	43	44	Ground
E1	45	46	Ground
E0	47	48	Ground
+5V	49	50	Ground

◆ Block Diagram

ONYX-MM-DIO BLOCK DIAGRAM

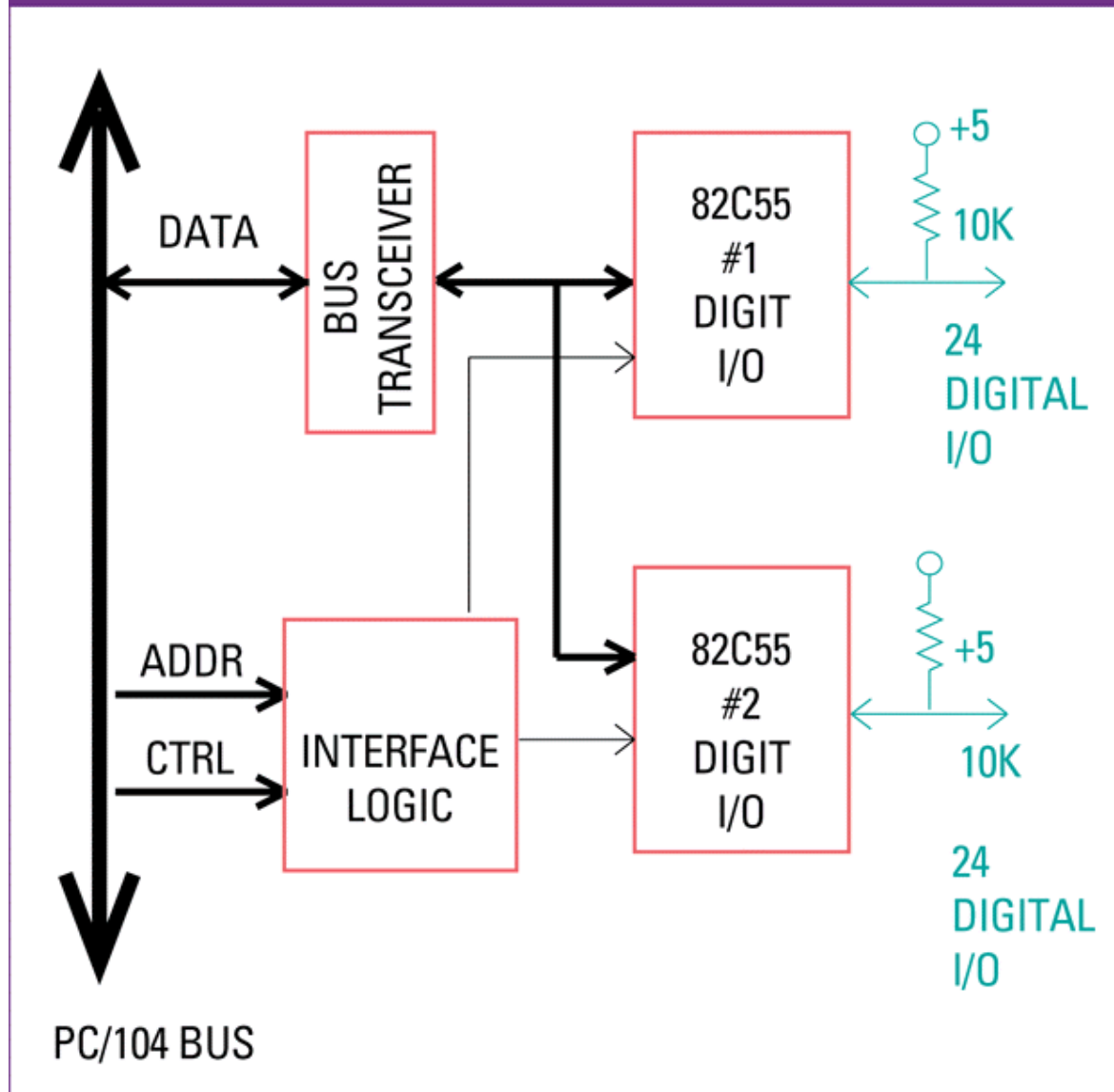

◆ Cables

Onyx-MM requires 2 cables for the 48 GPIO signals. Each cable provides 3 8-bit ports along with +5V and ground connections.

Cable	Description	Drawing
C-50-18	50-conductor .1" pitch 18" ribbon cable, Data acquisition Cable (Each board uses 2)	Show

◆ Specifications

Digital I/O

Chip	82C55A (qty. 2)
Number of I/O lines	48
Direction	Programmable in groups of 4 or 8
Input voltage	

Low:	-0.5V min, 0.8V max
High:	2.0V min, 5.5V max
Output voltage	
Low:	0.0V min, 0.4V max
High:	3.0V min, Vcc -0.4V max
Output current	±2.5mA max, each line
Pullup resistors	10KΩ all input lines

General

Power supply	+5V ±10% @ 100mA typical, all outputs open
Temperature	-40°C to +85°C
PC/104 Bus	8 bits
Weight	2.3 oz/65g
MTBF	OMM-DIO-XT 1,714,901 hours
RoHS	Compliant

◆ Models and Accessories

Onyx-MM-DIO

available models:

OMM-DIO-XT Onyx-MM 48 Digital I/O only Extended Temperature Min Order Quantity

Please [login](#) or [signup](#) for an online quote request.

Cables and accessories

available models:

C-50-18 50-conductor .1" pitch 18" ribbon cable (Each board uses **2**)

Please [login](#) or [signup](#) for an online quote request.

www.diamondsystems.com | [Sunnyvale, California USA](#) | [+1-650-810-2500](tel:+16508102500) | sales@diamondsystems.com