

REC37 SERIES

Hermetically Sealed Contactors

PRELIMINARY

350A CONTINUOUS DUTY
1500V SYSTEM VOLTAGE



FEATURES

SPST Normally Open High Voltage Contactors

- Hermetic seal with gas fill
- Optional auxiliary contacts – for main position feedback
- Integrated coil economizer to reduce coil holding power
- Meets RoHS 2011/65/EU
- CE certified
- IEC60947-5-1 compliant
-



PERFORMANCE

TABLE 1. SPECIFICATIONS	
CHARACTERISTIC	MEASURE
Contact Arrangement	Form X, SPST NO
Max Switching Voltage	1,500 VDC
Dielectric Withstand Voltage Contacts to Coil	5,375 VAC, 1 minute
Dielectric Withstand Voltage Across Open Contacts	5,375 VAC, 1 minute
Continuous Current (120mm ² conductor)	350A
Overload Current	1 minute 5 Minutes
	1000A 500A
Make and Break	See table
Max Short Circuit Current -1 second	3,000 A
Min Insulation Resistance	1,000 Mohm @ 1,000V
Contact Voltage Drop (Max)	125mV @ 250A
Operate Time (Max, incl bounce)	25ms
Release Time (Max)	12ms
Shock - Functional, 1/2 Sine, 11ms	20G
Shock - Destructive, 1/2 Sine, 11ms	50G
Operating Temperature	-40°C to 75°C
Ingress Protection	Exceeds IP69, (Hermetically sealed)
Mechanical life	200,000
AUXILIARY CONTACTS	MEASURE
Contact Arrangement	SPST
Continuous Current	2A
Minimum Current	100mA @ 8V
COIL	MEASURE
Nominal Voltage	9-36 VDC
Pick-up Voltage (Max)	9 VDC
Drop-out Voltage (Min)	6 VDC
Inrush Current (Max)	3.8A
Holding Current	0.13A @ 12 VDC 0.07A @ 24 VDC

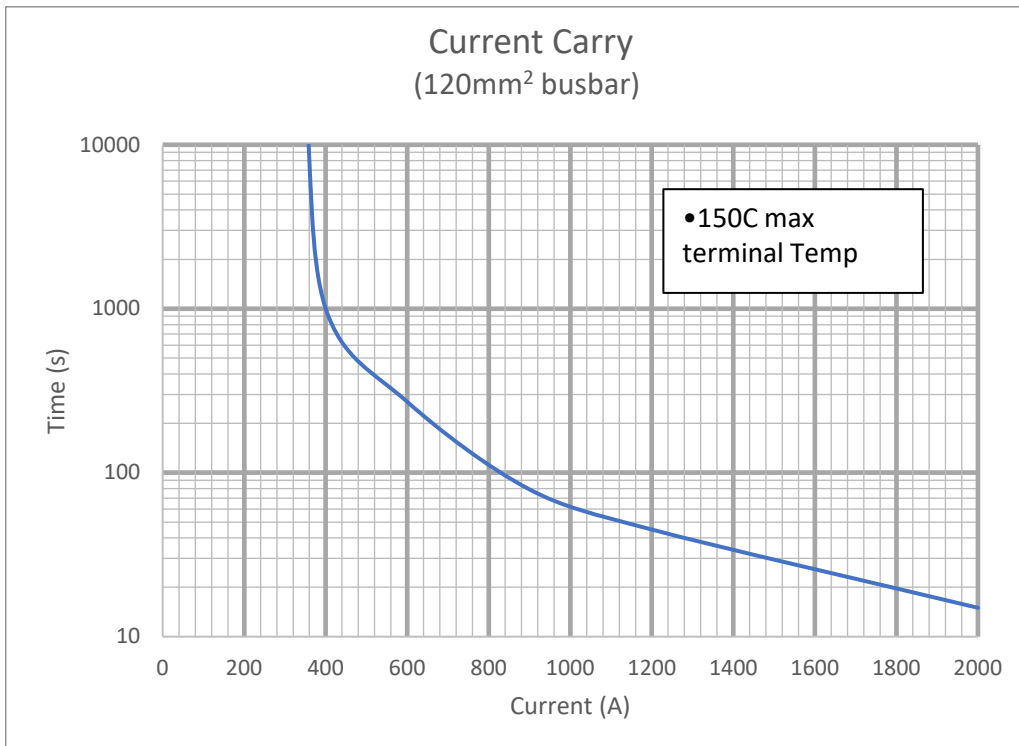

TABLE 2. RESISTIVE LOAD SWITCHING (MAKE / BREAK DATA)		
POLARITY SENSITIVE VERSION	CURRENT	CYCLE S (1 cycle = 1 make + 1 break)
450V	250A	10,000
650V	250A	2,000
1000V	250A	250
1000	100A	2,500
1500V	250A	10
1500V	10A	25,000

OPTIONS

TABLE 3. PRODUCT NOMENCLATURE				
	CONTACT POLARITY	MOUNTING	COIL	AUXILIARY CONTACTS
REC37	P Polarity Sensitive	1 Bottom Mount	J 9-36V internal PWM	X None A Normally Open

PRODUCT DIMENSIONS [mm]

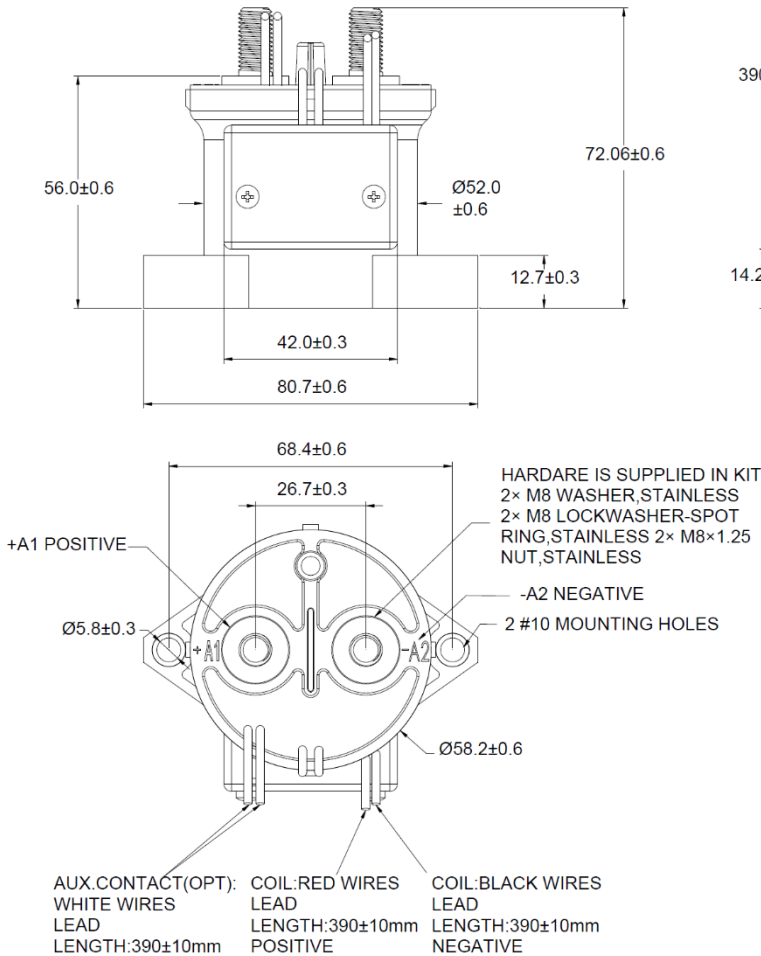

TABLE 4. DIMENSIONAL AND INSTALLATION	
CHARACTERISTIC	MEASURE
Weight	430g (0.95 lb)
Mounting Position	Any / Not Position Sensitive
Package Quantity	20
Install Torque M8 Main Terminals	9-11Nm (80-97 in-lb)

NOTES

- Polarity Sensitive versions are marked +A1 and -A2 for the power terminals. For applications that require the contactor under load, please ensure current is flowing from the +A1 to the -A2 terminal when breaking/opening under load For Bi-Directional versions the direction of current does not matter when breaking under load
- Attached cables and busbars directly to the main terminal pad using the recommended install torque. Do not use washers or other materials between the contactor and the conductor. This will ensure the lowest possible contact resistance
- Avoid excessive coil voltages. Exceeding the ratings on the datasheet may result in high coil temperature and coil failure
- Contactor may be used above Max Switching Voltage if the application does not require significant load breaking. Please contact Rincon Power to discuss in more detail