

**DIAMOND
-MM-
16RP-
AT** PC/104-
Plus 16-Bit
Analog I/O
Module with
Autocalibration



FEATURES

- 16 analog inputs, 16-bit resolution
- 100KHz max sampling rate
- Programmable gain and range
- FIFO support and interrupt-based A/D data transfer with Full flag and Underflow flag for better monitoring
- 4 12-bit analog outputs
- 16 digital I/O lines with choice of 8 in + 8 out, 16 out, or 16 in
- 5V/3.3V logic level operation
- Rugged -40°C to +85°C operation
- Drop-in upgrade for Diamond MM-16-AT

◆ Overview

The DMM-16RP-AT features top performance and flexibility for a mid-range price. It has 16 single-ended / 8 differential analog voltage inputs with both unipolar and bipolar input ranges, programmable gain, and a maximum sampling rate of 100KHz. The 4 D/A channels and 16 digital I/O lines provide additional real-world control and monitoring capability. The full -40 to +85oC industrial temperature operation ensures reliable and accurate performance in any embedded system application. A fully-featured software library with example programs and a graphical user interface completes the solution to

make the DMM-16RP-AT a solid choice for PC/104-Plus embedded systems requiring analog I/O.

◆ Block Diagram

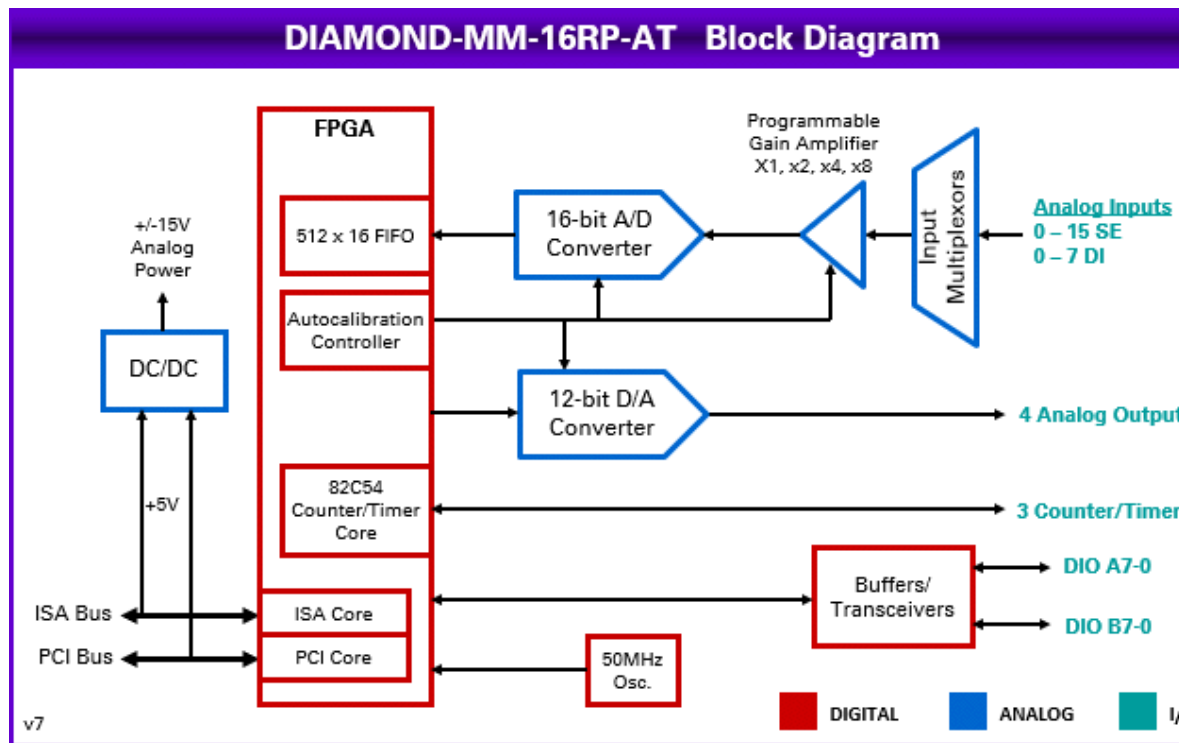

◆ Analog Inputs

The 16 16-bit analog input channels feature programmable gains of 1, 2, 4, and 8, as well as programmable unipolar/bipolar range, for a total of 7 different input ranges. Maximum sampling rate is 100KHz (total for all channels). Both single-channel and multi-channel scan sampling modes are supported. A 512-sample FIFO combined with interrupt data transfers enables the board to operate reliably at full speed in any operating system and reduce the overall load on the processor, by reducing the overall interrupt rate and eliminating the need to handle individual read operations for each sample. The A/D can be triggered with a software command, the on-board programmable timer, or an external signal. These features give you maximum flexibility to configure the board to your application.

◆ Analog Outputs

The board also has 4 12-bit analog voltage outputs with multiple unipolar and bipolar output ranges. The DACs support individual and simultaneous update capability. A programmable output range feature lets you set the output range via software anywhere between 0V and 10V with 1mV precision in both unipolar and bipolar modes. For higher volume applications, the D/A chip can be removed for cost reduction.

◆ Autocalibration for Highest Accuracy

Both analog inputs and outputs benefit from our unique multi-range autocalibration process. Multiple on-board precision references with high temperature stability are used to calibrate each analog input range individually, thereby ensuring the highest degree of

accuracy over the life of the product. The analog outputs are also fed back to the autocalibration circuit for precise output range calibration.

◆ Digital I/O Features

DMM-16RP-AT digital features include a 32-bit counter/timer to provide A/D sampling control and a 16-bit counter/timer for general purpose counting and rate generator functions. The board also provides 16 programmable digital I/O lines grouped into two 8-bit ports, each of which can be programmed for either input or output. The digital I/O lines feature jumper-selectable 3.3V / 5V logic levels and 10K pull-up / pull-down resistors.

◆ Dual Bus Interface

DMM-16RP-AT is implemented as a PC/104-Plus board, however it features a novel dual bus interface. Both ISA and PCI connectors are installed and connected to the FPGA. The board will autoselect the PCI bus when present, however a jumper can be used to disable the PCI bus and force the board into ISA bus mode if desired. This allows the board to be used in both PCI and ISA bus PC/104 systems (assuming the PCI-104 connector does not pose a mechanical interference problem with other boards in the system). The board uses 3.3V signaling on the PCI bus and must be used only with 3.3V PCI bus SBCs. The ISA bus uses the standard 5V logic levels.

◆ Software Support

DMM-16RP-AT is supported by our Universal Driver software for Windows and Linux. Universal Driver features a library of functions for C-language software development that simplifies all I/O operations, including administrative functions such as calibration. Example programs are provided in both source code and executable format for demonstration and immediate usability. Our unique Control Panel program provides a graphical user interface for both Windows and Linux that can control all the board's features in real time. It can be used for proof of concept, prototyping, and diagnostics. Universal Driver may be ported to other operations systems by customer request.

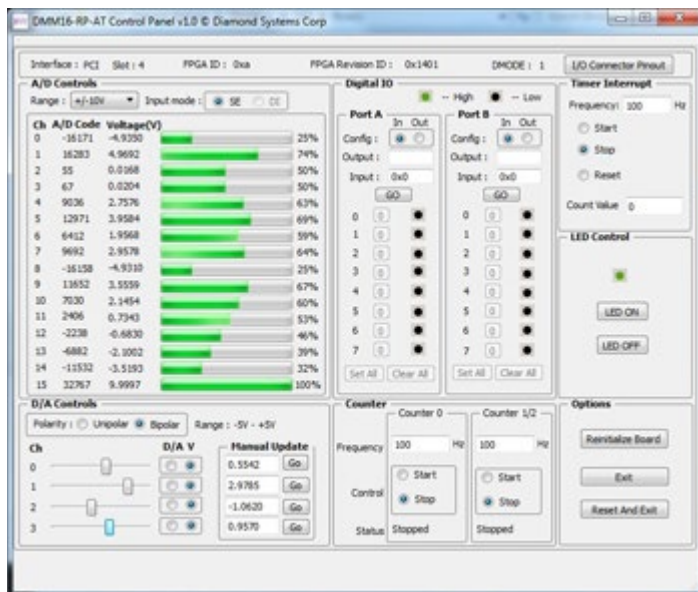

◆ Specifications

Analog Inputs	
Number of inputs	8 differential or 16 single-ended (user selectable)
A/D resolution	16 bits (1/65,536 of full scale)
Bipolar ranges	±10V, ±5V, ±2.5V, ±1.25V, ±0.625V
Unipolar ranges	0-10V, 0-5V, 0-2.5V, 0-1.25V
Input bias current	3nA max
Overvoltage protection	±35V on any analog input without damage
Input Impedance	10 ¹³ ohms
Nonlinearity	±3LSB, no missing codes
Conversion rate	100,000 samples/sec. max with interrupts
Conversion trigger	Software trigger, internal pacer clock, or external TTL signal
Input FIFO	512 samples, 256-sample interrupt threshold
A/D interrupt	End of A/D conversion End of A/D scan FIFO half-full
Calibration	A/D and D/A circuits calibrated under software control using on-board precision references and EEPROM storage
Analog Outputs	
Number of outputs	4
D/A resolution	12 bits (1/4096 of full scale)
Output ranges	Fixed: ±5, 0-5V Programmable: Anywhere between 0V and 10V in 1mV increments Reset: All channels reset to mid-scale (0V for bipolar ranges)
Output current	±5mA max per channel
Settling time	6μS max to 0.01%
Relative accuracy	±1 LSB
Nonlinearity	±1 LSB, monotonic
Digital I/O	
Number of lines	16, organized as 2 8-bit ports

Logic Levels	3.3V / 5V jumper selectable
Termination	10K ohm pull-up / pull-down resistors, jumper selectable
Input voltage	Vlogic = 5V
Logic 0	1.65V max
Logic 1	3.35V min
Output voltage	Vlogic = 5V
Logic 0	0.44V max, Iout = 24mA
Logic 1	3.76V min, Iout = -24mA
Input voltage	Vlogic = 3.3V
Logic 0	0.80V max
Logic 1	2.00V min
Output voltage	Vlogic = 3.3V
Logic 0	0.44V max, Iout = 24mA
Logic 1	2.25V min, Iout = -24mA
Counter/Timers	
A/D Timer clock	32-bit down counter
General purpose	16-bit down counter
Clock source	10MHz on-board clock or external signal
General	
Bus Interface	Dual PCI (3.3V) and ISA (5V) buses supported; Autoselects for PCI bus; manual override option
Power supply	+5V ±5% @ 375mA typical
±15V output current	±10mA max with DACs unloaded
Operating temperature	-40°C to +85°C tested and guaranteed
Weight	80g / 2.84oz
RoHS	Compliant

◆ Ordering Information

◆ Models and Accessories

DIAMOND-MM-16RP-AT

available models:

DMM-16RP-AT Diamond-MM Autocalibrating 16-ch 16-bit A/D +4-ch 12-bit D/A Extended Temp. Available
PCI Bus

Please [login](#) or [signup](#) for an online quote request.

www.diamondsystems.com | [Sunnyvale, California USA](#) | [+1-650-810-2500](tel:+16508102500) |
sales@diamondsystems.com